



# SCINCO PMc Series

## High-Throughput Surface Area and Porosity Analyzer

The **SCINCO PMc Series** offers a fully automated, high-performance solution for the precise measurement of surface area and pore size distribution in both porous and non-porous materials. Ideal for analyzing catalysts, zeolites, MOFs, and battery materials, it combines a robust vacuum-volumetric system with intuitive software, supporting both standard and advanced adsorption techniques.

Available in 1-, 2-, or 4-station configurations, the **SCINCO PMc Series** features a shared  $P_0$  transducer with support for simultaneous saturation vapor pressure measurements. Users can select between a dedicated pressure transducer per station for maximum speed or a shared-sensor configuration for cost-effective operation—ensuring flexibility for various lab environments.

A single large-volume dewar supports multiple analysis ports concurrently, making the **SCINCO PMc Series** an ideal solution for high-throughput laboratories requiring space-efficient, parallel sample processing without compromising analytical precision.

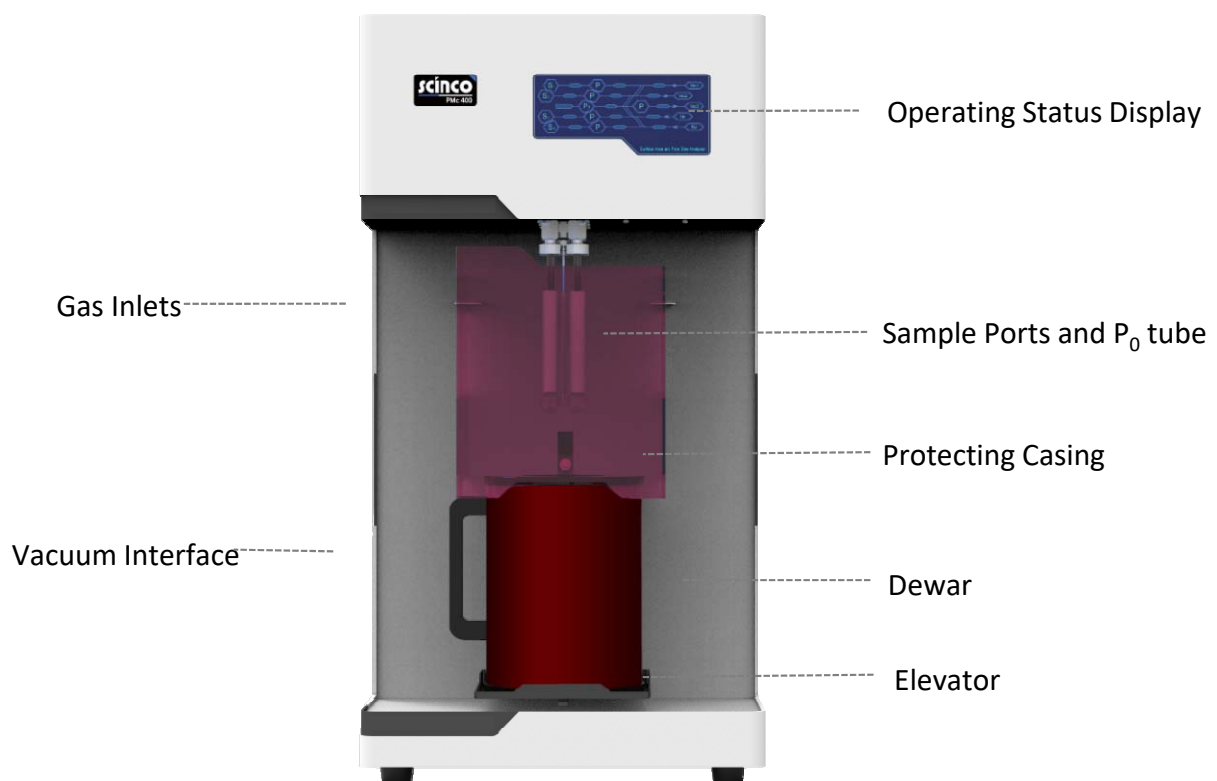

SCINCO PMc400 Series

## Customizable Configuration for Throughput Analysis Needs

The SCINCO PMc series offers a scalable solution with up to four high-resolution measurement stations for precise pore size and surface area analysis. For increased throughput, additional instruments can be linked via LAN, expanding to 12 analysis ports with centralized and remote-control capabilities.

## High Sensitivity & Reproducibility

The SCINCO PMc Series delivers precise and reliable surface area and porosity data, with a BET detection limit as low as 0.1 m<sup>2</sup> absolute and 0.01 m<sup>2</sup>/g specific.

It offers outstanding reproducibility within 1% on standard reference materials like BAM P115—ensuring confidence in repeated analyses.

## Cryo Tune™ (Optional Feature)

Unlock advanced temperature control with Cryo Tune™, an optional low-temperature cold bath system designed for precision adsorption studies. Fully integrated with Sync software, Cryo Tune™ allows users to effortlessly conduct adsorption isotherm measurements across a range of temperatures.

## Optimized Manifold Contamination Control

A two-step filtration system protects the manifold from particulates reducing contamination risks and extending instrument life. Combined with stainless steel construction and high-cycle bellows valves, the system ensures clean, reliable operation even in high-throughput environments.

## Extended Analysis Duration

SCINCO PMc analyzers are equipped with large 3-liter Dewar flasks that allow over 90 hours of continuous analysis. The system supports live refilling during experiments, ensuring uninterrupted data collection during long runs and complex isotherm acquisitions.

## Precision-Engineered Hardware

Built with stainless steel and vacuum-brazed manifolds, the system features ultra-durable bellows valves rated for over 5 million cycles. Temperature control maintains  $\pm 0.05$  °C stability, while 32-bit pressure sensors provide high-resolution, accurate data capture.

## Compact & Lab-Ready

All models share a compact footprint of 51 × 53 × 93 cm, making them ideal for space-conscious labs. Despite their compact size, PMc analyzers are fully equipped for both research-grade and industrial applications, offering power, durability, and precision in one system.

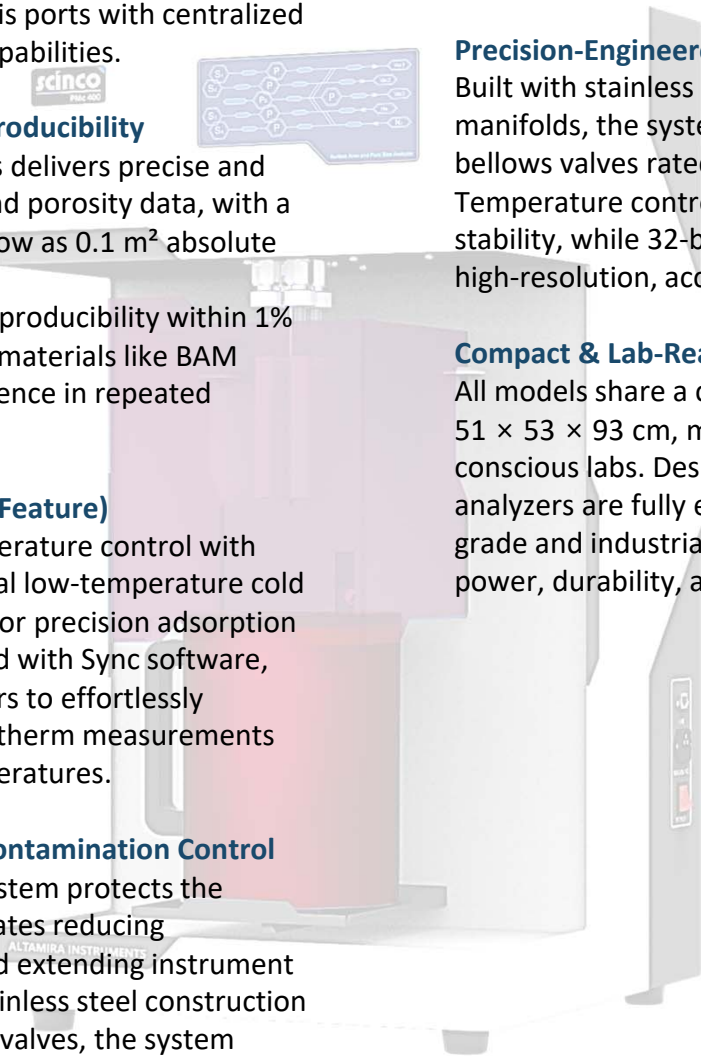
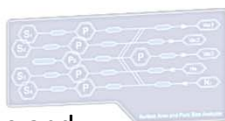

**SCINCO PMc Series** analyzers are driven by a multilingual, user-friendly software suite that supports:

- Control of up to 8 instruments from a single PC
- Built-in method libraries for fast setup and repeatability
- Customizable analysis profiles with real-time system feedback
- Automated leak detection and guided maintenance routines
- CFR 21 Part 11-ready sample tracking, including ID and method history
- Visual instrument status interface for monitoring analysis in progress

Additional capabilities include void volume correction, supercritical  $P_0$  handling, temperature control with **CryoTune**, and compatibility with up to 6 gases per station.

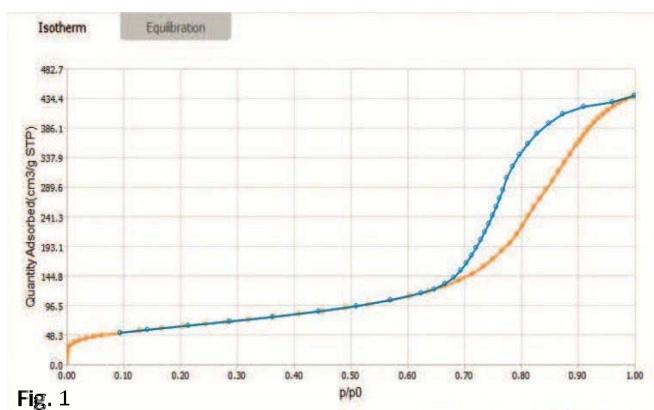

Fig. 1

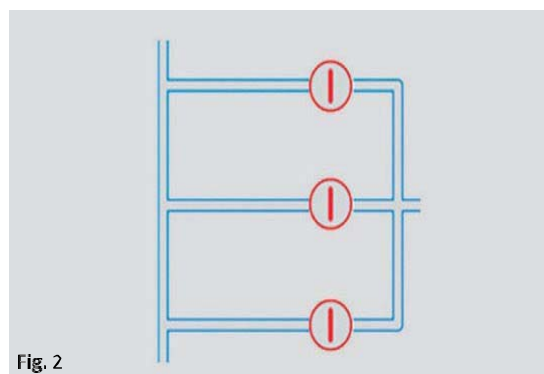

Fig. 2

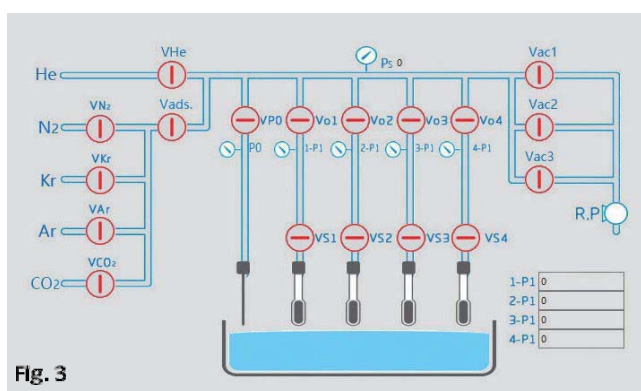

Fig. 3

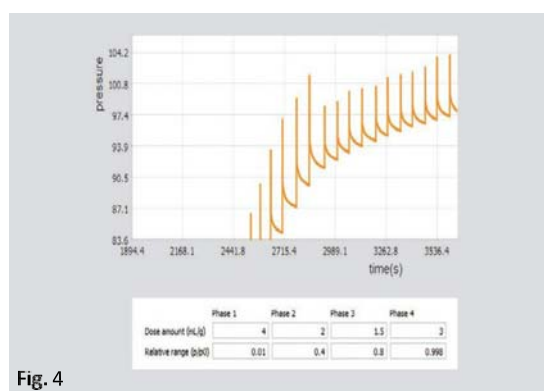

Fig. 4

Figure 1: Isotherm

Figure 2: 3-stage evacuation to prevent sample fluidization

Figure 3: Main software screen

Figure 4: Interactive software screen

# SPECIFICATIONS

## Data Analysis Capabilities:

- Isothermal absorption and desorption curve
- BET specific surface area (single and multiple point)
- Langmuir surface area
- Statistical thickness surface area. (STSA)
- HK pore size analysis
- SF pore size analysis
- NLDFT pore size distribution
- Total pore volume
- t-plot analysis

<i>Specific Model</i>	<b>110</b>	<b>210</b>	<b>220</b>	<b>420</b>	<b>440</b>
<i>Analysis Ports</i>	1	2	2	4	4
<i>Po Transducer</i>	1	1	1	1	1
<i>Analysis Pressure Transducer</i>	1	1	2	2	4
<i>Surface Area</i>	≥ 0.0005 m <sup>2</sup> /g				
<i>Pore Size</i>	0.35-500 nm				
<i>Pore Volume</i>	≥ 0.0001 cm <sup>3</sup> /g				
<i>Pump</i>	Mechanical Pump (minimal 5.0 x 10 <sup>-4</sup> mmHg)				
<i>P/P0</i>	10 <sup>-5</sup> - 0.998				
<i>Accuracy PTs</i>	1000 mmHg (+/- 0.2% F.S.)				
<i>Adsorbates</i>	N <sub>2</sub> , CO <sub>2</sub> , Ar, Kr, H <sub>2</sub> , O <sub>2</sub> , CO, NH <sub>3</sub> , CH <sub>4</sub>				
<i>Dimensions</i>	510 x 530 x 930 mm (16.1 x 20.8 x 36.6 inches)				
<i>Weight</i>	45 kg / 99 lbs (maximum depending on configuration)				



Website: [www.scinco.com](http://www.scinco.com)  
E-mail: [scinco@scinco.com](mailto:scinco@scinco.com)

**SCINCO** 627, Bongeunsa-ro, Gangnam-gu, Seoul 135-873 Korea  
Tel : +82-2-2143-8200 Fax : +82-2-2143-8355

**R&D Center** 746, Daedeok-daero, Yuseong-gu, Daejeon 305-348 Korea  
Tel : +82-42-610-7400 Fax: +82-42-610-7500